



Beginners Guide to R/C Flight

Copyright 1999 - 2003© [Howard Sullivan](#)



Introduction

Radio controlled aircraft modeling is one of the most exciting hobbies available. It involves many interests, disciplines, and skills. Some of these are aerodynamics, electronics, mechanics, drafting and design, composite material construction, and woodworking, and these are in the airplane alone. There are many other fields of interest in the hobby of aircraft modeling; far too many and too varied to try to list. Many people find that many new skills must be learned before they are ready to begin to learn to fly. The hobby is constantly changing as new technology is developed. A new modeler may become frustrated at times but certainly not bored.

To reduce the chance of frustration, a new modeler should become involved with other modelers in order to learn the necessary skills. This may involve simply visiting a flying site and becoming acquainted with experienced modelers or joining a club. These modelers are a source of knowledge and experience that can be invaluable to the new modeler when he begins to build his first aircraft and when he begins to learn to fly. An experienced modeler can act as an R/C flight instructor to teach a new person the skills required to fly the aircraft properly and to avoid the inevitable crash.

New modelers must realize that a radio controlled model aircraft is not a toy. It is a true aircraft in that it flies and operates by the same principles as a full-scale aircraft with the difference being the size and weight. The average model will fly in a range of 20 to 60 MPH and weigh 5 1/2 to 6 pounds. The force of the model hitting an object can be devastating especially if it hits a person. Models must be controlled properly both for enjoyment and for safety. The skills required to accomplish this must be learned from an experienced modeler.

Before purchasing any equipment, the beginner should ask himself, "Is this a hobby I want to try to see if I like it or is it a hobby I am going remain involved in for years to come?" If the beginner is going to remain in the hobby for years, he might consider buying more expensive equipment such as a ball bearing engine and a six (6) channel radio system. Otherwise, he should try to keep his initial outlay as low as possible. A beginner can limit his spending to as little as \$200 by buying good used equipment but care must be taken to ensure that the equipment is reliable. At the other end of the scale, a beginner could easily invest \$1000 on new equipment if he is

not prudent with his purchases.

The topics that will be covered will be relating to a beginner or novice and a trainer airplane. The information relating to all aspects of R/C powered flight can be overwhelming even to the most seasoned pilot. Those disciplines relating to the more advanced levels of R/C flight will most likely be learned as the skill level of the novice improves and the goals are more defined.

The Topics are listed below:

- [Introduction](#)
- [Basics of Flight](#)
- [The Basic Trainer](#)
 - [Some of the Best Trainers](#)
- [The Basic Radio System](#)
- [The Basic Engine](#)
 - [Some of the Best Engines](#)
- [Construction of the Trainer](#)
- [Effects of the Control Surfaces](#)
- [Field Equipment](#)
- [Learning to Fly](#)
 - [Using a Flight Simulator](#)
 - [R.C. Flight Simulators](#)
- [Getting Started](#)

[Return to Beginners Page](#)

Basics of Flight

A beginner should understand the basic concepts of flight. The theories behind the physics of flight are covered in many volumes of books. There are different and sometimes conflicting theories and arguments as to how airplanes fly, but the one accepted principle is that lift is generated as a result of the air pressure on the bottom of the wing being higher than the air pressure on the top of the wing.

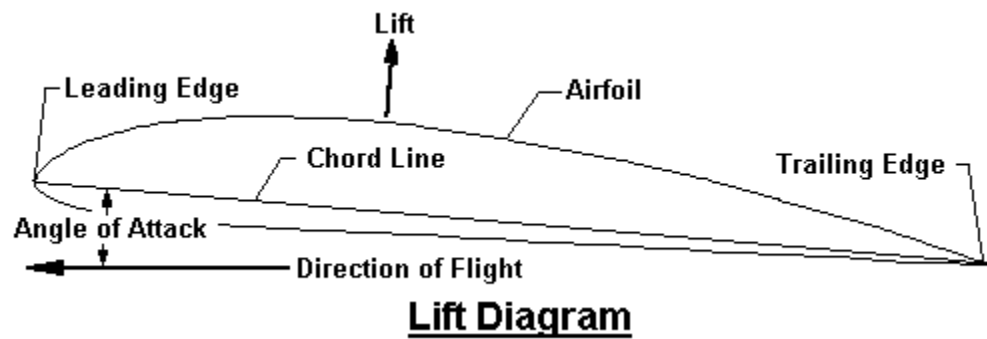

The Lift Diagram shows some of the basic terms relating to a wing section. These terms are common to R/C flight.

Airfoil	-	The cross section of the wing
Angle of Attack	-	The angle between the chord line and the relative direction of flight
Chord Line	-	The line between the leading edge and the trailing edge of the airfoil
Direction of Flight	-	The relative direction of the wing in relation to still air
Leading Edge	-	The most forward edge of the wing
Trailing Edge	-	The most rearward edge of the wing

There are four (4) primary forces that act on an aircraft in flight; thrust, lift, drag, and weight. Thrust is the force applied by the combination of engine and propeller acting to pull the aircraft forward. Drag is the resistance against the aircraft by the force of the air against the forward facing surfaces. Weight is caused by gravity. In order for a constant speed to be maintained, thrust and drag must be equal. In order for a constant altitude to be maintained, lift and weight must be equal.

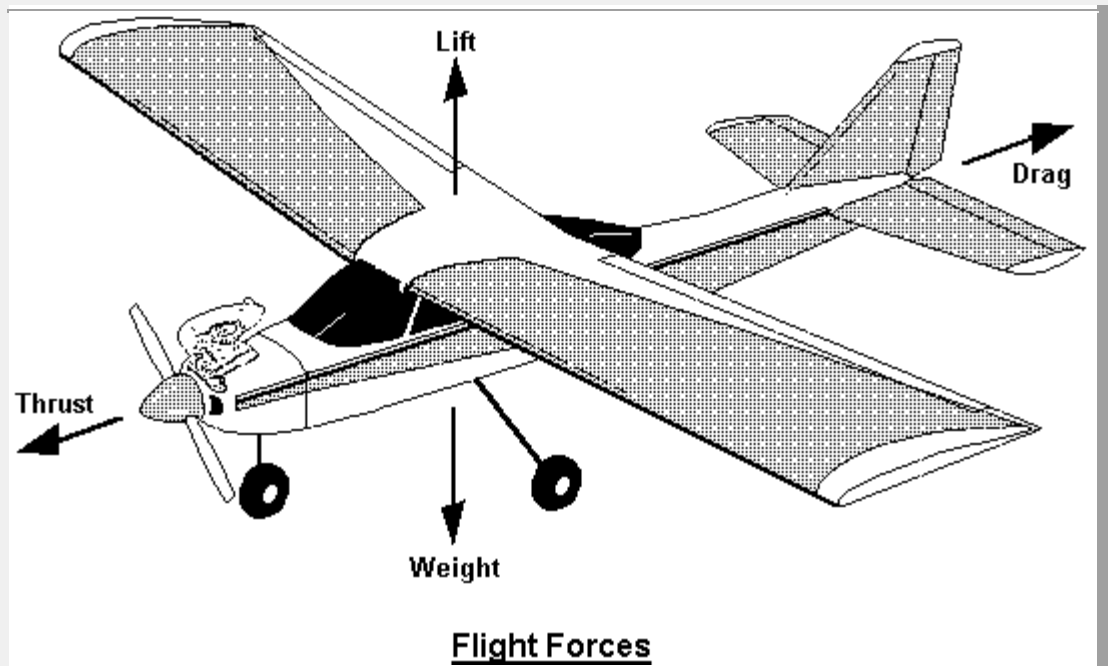

Lift increases as the velocity of the air passing over the wing increases or as the angle of attack increases as long as the flow of air over the wing remains smooth. Actual flight is attained when the force of the lift equals weight.

An aircraft pivots about three (3) axes; the yaw or vertical axis controlled by the rudder, the pitch or lateral axis controlled by the elevator, and the roll or longitudinal axis controlled by the ailerons. It can pivot about any one of these individually or in combination based on the control surfaces that are moved and the direction of the movement.

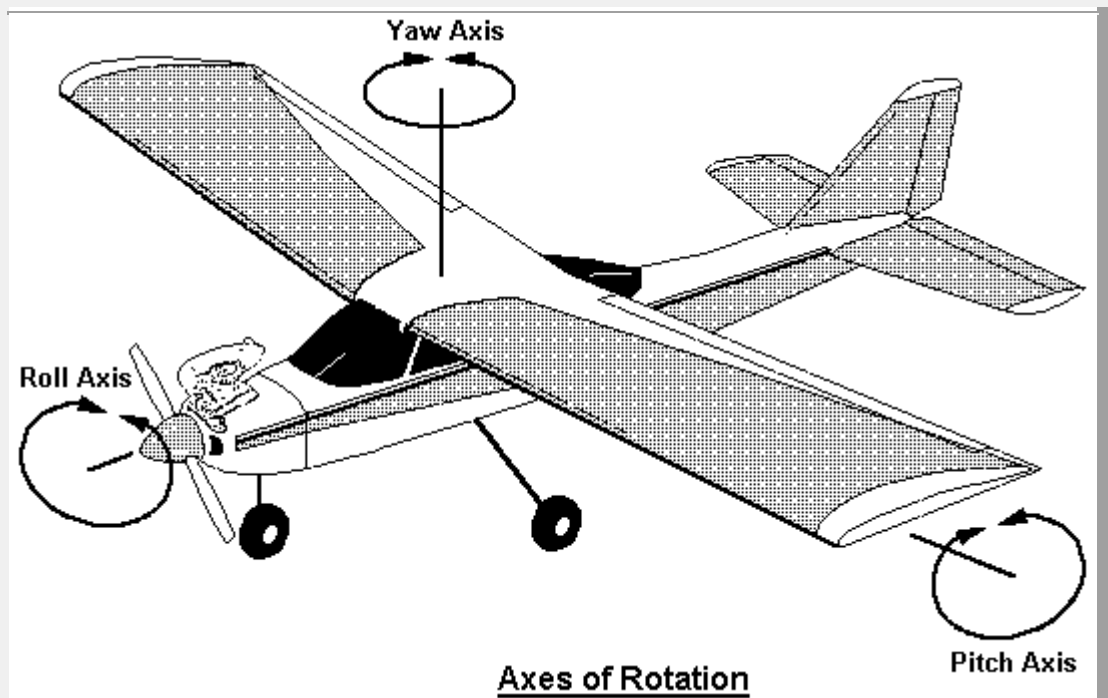

When the rudder is moved to the right, the aircraft will rotate to the right about the yaw axis and vice versa. When the elevator is moved up, the aircraft will pitch the nose upwards. The ailerons move in opposite directions. When the left aileron is moved up and right one down, the aircraft will rotate to the left and vice versa.

The Basic Trainer

Quite often a person has an interest in model airplanes and visits a local flying field just to observe. He sees all types of airplanes from trainers to pattern planes to scale World War II fighter planes. His interest is piqued by all the fabulous looking models. He thinks, "I have to have one of those Mustangs." He immediately sets out trying to find a P-51 model to begin his modeling hobby. This is a serious mistake. Many hours of training and practice are involved before a beginner has the ability to handle the more advanced models. A beginner must realize the dedication that is required to gain the ability to fly the type of model that initially spawned his interest. He must begin the hobby with a basic trainer and progress through different levels of models until his goal is reached.

A trainer is a specific type of model aircraft that is designed to be stable in flight. This means that it has an inherent ability to correct itself and overcome the rotational forces applied so that it regains straight and level flight. Most trainers are designed to that they remain stable in slow flight so that they are easy to land.

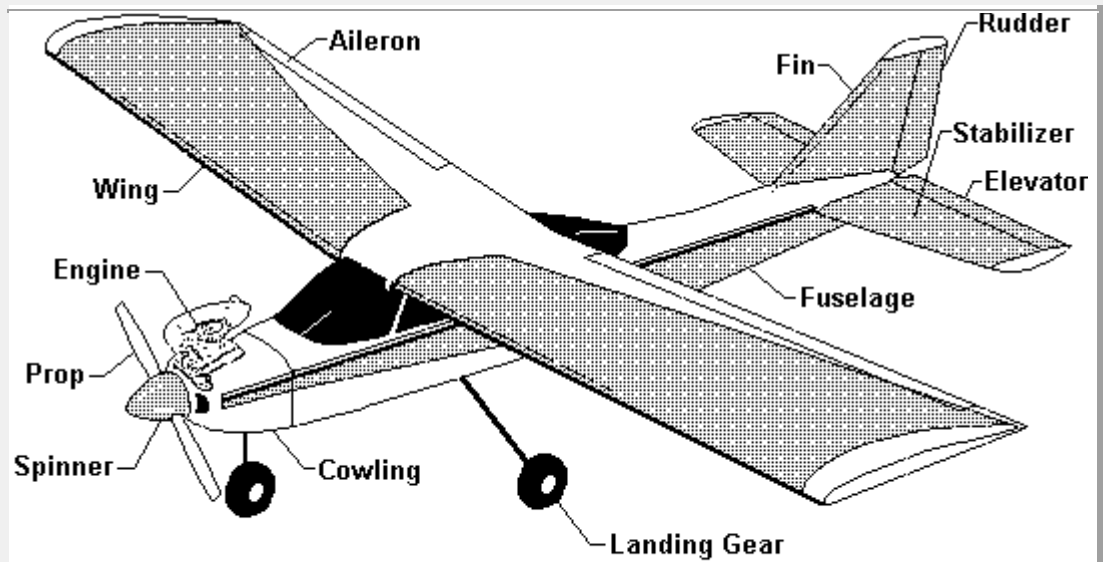

Basic Trainer

The Basic Trainer diagram shows the components of a common trainer.

Aileron	- The moveable portion of the wing which causes a change about the roll axis
Cowling	- The part of the fuselage which covers the engine
Engine	- A 2 - cycle reciprocating machine which provides the motivational power
Elevator	- The moveable portion of the horizontal stabilizer which causes a change about the pitch axis
Fin	- Properly known as vertical stabilizer which provides stabilization about the yaw axis
Fuselage	- The main body of an aircraft that holds the componets and cargo
Landing Gear	- The supporting structure of an aircraft including landing gear struts and wheels
Propeller (Prop)	- The combination of blades which provide thrust
Rudder	- The moveable portion of the vertical stabilizer which causes change about the yaw axis
Spinner	- Covering over the propeller hub
Stabilizer	- Properly known as horizontal stabilizer which provides stabilization about the pitch axis
Wing	- The horizontal surfaces which provide the lifting forces

There are certain criteria that a trainer should have in order to be satisfactory for a beginner.

1. **High Wing** - A high wing model is inherently more stable than a low wing model due to pendulum effect. Since the weight of the model is below the wing, the fuselage tends to swing downward like a pendulum in order to equalize forces.
2. **Flat Bottom Wing** - The wing cross section should have a virtually flat bottom. This type of cross section has more gentle flight characteristics that are necessary for a beginner.
3. **Dihedral** - The wing should have some dihedral. This means that the tips of the wings are higher than the center. The effect of the dihedral is to try to equalize forces and keep the wings level or to return the wings to a level orientation
4. **High Aspect Ratio** - The ratio of the wing length or span should be at least 5 1/2 times the width or chord. This will reduce the rate at which the model responds to command input allowing more time for a beginner to react.
5. **Constant Chord** - The width of the wing should be the same from the center or root to the end or tip. This distributes the weight of the airplane evenly over the entire surface of the wing.
6. **Low Wing Loading** - The weight of the model divided by the area of the wing should not exceed 19 oz./sq. ft. This reduces the speed required to maintain an acceptable rate that the model descends when the power is reduced resulting in a lower landing speed.
7. **Moderate Size** - Most trainers are for engine sizes between .15 and .60. The smaller ones are more susceptible to the effects of wind and normally the wing loading is higher simply because of the weight of the radio equipment. The larger sizes are easier to fly and easier to see but are more difficult to transport. Most trainers are for .40 size engines. These trainers have been widely accepted as the optimum size.
8. **Structurally Sound** - A trainer must be able to take the abuses imposed by a beginner. This is especially true for hard landings. It must be able to withstand minor crashes with minimal damage. It should be relatively easy to repair.

A trainer that meets these guidelines will give the beginner excellent service without the frustration that can occur with an inappropriate model. With proper instruction, the beginner can progress quickly to his solo flight and on to the novice stage and still get years of sport flying from the trainer.

There are several trainers on the market that meet and far exceed the guidelines. These range from the most basic kit to beautiful Almost Ready to Fly (ARF) models

and Virtually Ready to Fly (VRTF) complete with engine and radio. There are a lot of considerations when choosing a trainer but the two most basic are time and money.

A trainer built from a kit has the advantage of being less expensive in some cases. It gives the builder the pleasure of building, the option of color and trim scheme, and the knowledge of the structure to perform repairs. The biggest disadvantage is the time required to construct the model when the beginner would rather be learning to fly. Another disadvantage in some cases is the emotional attachment the builder develops having spent many hours on his creation.

The big advantage of the ARF models is that they can be assembled in a matter of a few hours and the beginner can be ready to start his flying lessons. The disadvantages are the cost, the unknown structure that is sometimes weak, and the fixed color scheme. Most ARF models perform as well or almost as well as any kit built model on the market. Any beginner who purchases an ARF model should get an experienced modeler to check the model before assembly is started. An experienced modeler can point out areas that may need to be reglued or reinforced.

There are several models that are widely accepted as being the best in the field although there is disagreement as to which is the "All Time Best". The list is not an all-inclusive but includes those that are most widely accepted and therefore are most widely recommended by novices and seasoned veterans of the hobby. Some of the trainers are also available in .20 and .60 size but the .40 is the most widely accepted.

Some of the Best Trainers

NAME	SUPPLIER	DESCRIPTION
Stick 40+	Balsa USA	The most basic trainer kit available, inexpensive, easy to build, easy to fly, almost indestructible
Kadet LT40	SIG Mfg.. Inc	Very good quality trainer kit, relatively easy to build, easy to fly, excellent performance
Kadet Senior	SIG Mfg.. Inc	Very good quality trainer kit, difficult to build, very easy to fly, good performance
Eagle II	Carl Goldberg	Very good quality trainer kit, relatively easy to build, very easy to fly, good performance
Aerostar 40	Midwest	Very good quality trainer kit, relatively easy to build, easy to fly, very good performance
Telemaster 40	Hobby Lobby	Very good quality trainer kit, relatively easy to build, easy to fly, good performance

PT40 Mk II	Great Planes	Very good quality trainer kit, relatively easy to build, easy to fly, very good performance
Trainer 40	Thunder Tiger	Good quality ARF trainer, easy to assemble, easy to fly, excellent performance
Trainer 40 and 60	Tower Hobbies	Good quality ARF trainer, easy to assemble, easy to fly, very good performance

Most if not all of the models listed have been reviewed by one of the major model magazines. A beginner can get information from these reviews that may help in deciding which model to buy and the areas of assembly that need special attention. Regardless of the amount of advice that the beginner gets from experienced modelers, the final decision is the beginner's. The choice of a model is an individual choice and all the pros and cons must be weighed. Each person must decide which model is pleasing in appearance and performance and which one will meet his needs. The final consideration should be that the model should be considered disposable. Many trainers are destined for the junk pile when it has served its purpose.

The Basic Radio System

There are many modern radio systems from which the beginner can choose. There are several common brands including Futaba, Airtronics, JR, Hitch, and Ace. Each of these offers a wide range of options from a simple 2 - channel to a computer assisted 8 - channel system. The buyer is limited only by his budget. A beginner should discuss his choice of systems with his intended instructor. There are several reasons for doing this, the primary reason being that the student's systems must be compatible with the instructor's system if it will be used as a buddy box. This issue will be covered in more detail later.

All basic radio systems consist of four (4) basic components.

Transmitter	-	The unit which takes the input from the user through the gimbals or sticks, encodes it, and sends it to the aircraft
Receiver	-	The unit that receives the signal, decodes it, and routes it to the appropriate servo
Servos	-	The device that converts the decoded signal to mechanical force to operate a control surface
Batteries	-	The device that provides power for the other devices to operate

There are specific frequencies assigned by the Federal Communications Commission (FCC) for use with airborne R/C models. A beginner must ensure that the system that he chooses is tuned to one of these frequencies. Most radio system manufacturers

place a sticker on the outside of the carton that says, "For airborne use only". There is frequency reference chart available that lists the purposes of all of the frequencies that are assigned for R/C use.

The radio that is chosen must meet the 1991 specifications for narrow band receivers. The beginner need not know the actual requirements of these specifications because the systems are required to be certified to this standard. The owner's manual for the system will note that the requirements are met and many of the transmitters and receivers will have a gold sticker to signify this fact.

The radio system may transmit and receive on either an AM frequency or a FM frequency. The FM frequencies are less prone to interference than the AM frequencies although those using AM frequencies seldom have problems with interference. Some radio systems use an internal system, called PPM, to help to nullify interference.

Regardless of the brand of system, the number of channels, or the price, all transmitters have the same basic components. Transmitters may have additional switches, slides, and displays depending on the functions they perform but the basic components remain the same.

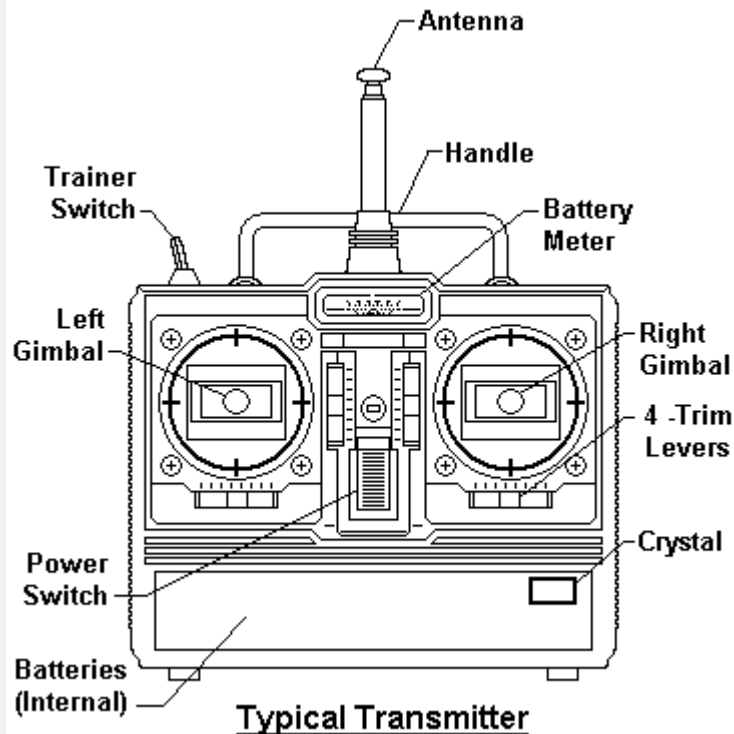

Antenna	-	The telescoping tube that transmits the signal
---------	---	--

Batteries	-	The device that provides power to the transmitter
Battery Meter	-	The device used to monitor the strength of the transmitter batteries
Crystal	-	The device that sets the radio frequency of the transmission
Gimbals (Stick)	-	The device that allows the user to input desired control movements into the transmitter
Handle	-	The device for carrying the transmitter
Power Switch	-	The switch used to apply battery power to the internal components of the transmitter
Trainer Switch	-	The switch used to allow an instructor to give control of a model to the student
Trim Lever	-	Slides used to adjust control surfaces during flight

There are two (2) primary modes of operation, meaning the way the gimbals are set up for operation. There are unsettled debates as to which mode is the easiest to use and best for a beginner. The modes of operation have become switched between the United States and most European countries. Mode I is primarily used in Europe while Mode II is used in the United States.

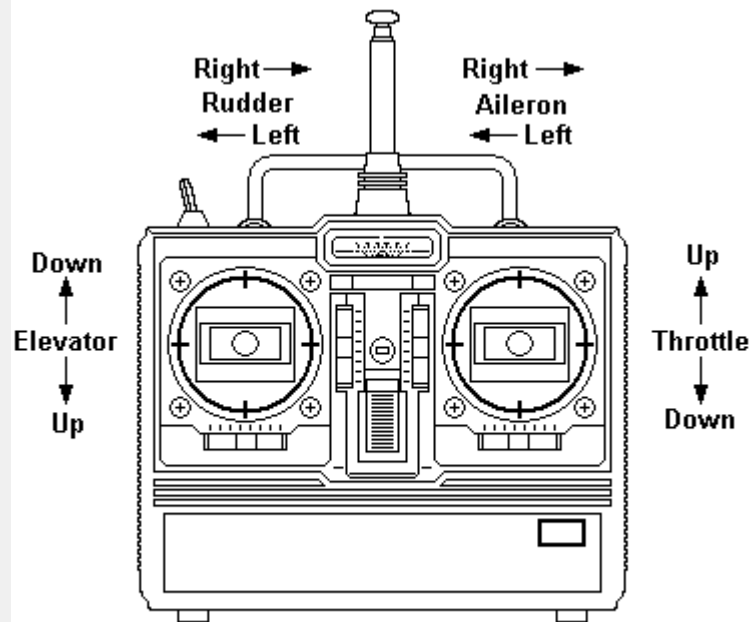

Mode I

Mode I started in the days of reed actuated proportional systems. The transmitters were uniformly set up in this manner. The thought was that the elevator and rudder or ailerons were the primary controls and each should be operated by an opposite hand for precision control. Later this carried over into the more modern proportional systems since this was the mode used by most modelers.

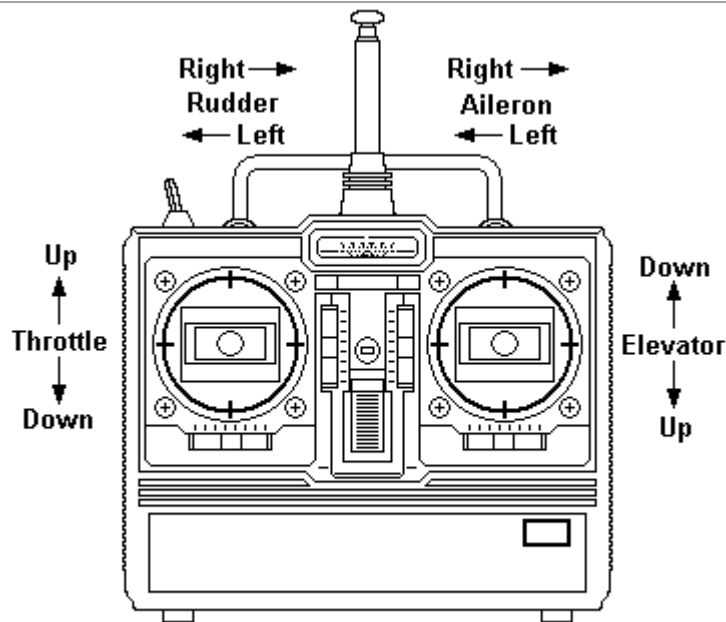

Mode II

In later years, the thinking changed to the Mode II configuration. More modelers believed that it was easier to control the primary surfaces effectively with the same hand. Mode II grew in popularity and is used almost exclusively in the USA. A beginner does not have to be concerned about which mode he should select since most manufacturers install the gimbals according to the most widely used mode for the nation to which the radio system is being shipped.

There have been discussions over the years involving the number of channels with which a beginner should start. Some people say that only three (3) channels should be used; rudder, elevator, and throttle. The argument here is that it is easier for a beginner to only be concerned with using the rudder to make turns and not be concerned with the ailerons. Others contend that four (4) channels should be used; rudder, ailerons, elevator, and throttle. The contention in this argument is that by not using ailerons, a beginner must go through a second phase of beginner training that being learning how to use ailerons. A four (4) channel system offers better control of the model during takeoffs and landings in cross wind conditions. The four (4) channel approach to training is more widely accepted today.

A beginner might consider buying one of the more advanced six (6) channel systems to get some of the features that are not available in the basic system such as dual rate controls. This feature allows the user to reduce the sensitivity of the sticks thereby reducing the chance of over controlling. If the beginner is relatively sure of future goals that involve the use of a six (6) channel system, he can consider this an investment in his future modeling and therefore save money. A lot must be determined before the initial purchase and should be discussed at length with experienced modelers, especially the intended instructor, before the purchase is made.

The Basic Engine

The primary engine type used by modelers today is a single cylinder, two (2) cycle, air cooled reciprocating engine that uses a glow plug ignition and a special fuel mixture of methanol, nitromethane, and castor oil. Most of the components of the engine are made of cast, forged, or machined aluminum. The power that can be achieved from these small engines is phenomenal and can vary greatly from one design to another. A typical inexpensive .40 size engine can produce 1.1 horsepower at 11,500 RPM. The same size racing engine can produce 2.4 horsepower at 20,000 RPM. All of these engines are the same in their basic components.

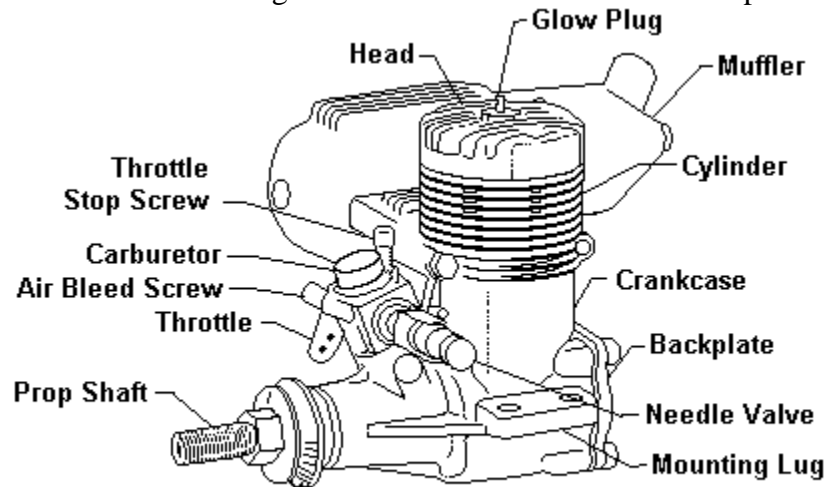

Typical Engine

Air Bleed Screw	- Screw for adjusting the amount of air allowed to bleed into the carburetor during idle
Backplate	- Cover over the rear of the crankcase
Carburetor	- Device which mixes fuel and air and controls the amount of mixture entering the engine
Crankcase	- Main body of the engine
Cylinder	- The section of the crankcase where combustion takes place
Glow plug	- Device which provides heat for ignition of the air/fuel mixture
Head	- The component which forms the end of the compression chamber of the engine
Mounting Lug	- The section of the crankcase used to mount the engine to the airplane
Muffler	- The device which reduces the noise level of the engine
Needle Valve	- The device used to adjust the air/fuel mixture

Prop Shaft	-	The main crankshaft which transfers the power of the engine to the propeller
Throttle Stop Screw	-	Screw for setting the lower limit of the throttle movement

The design of the engine affects its power output, reliability, and longevity. The prop shaft is supported by bushings or bearings. Wear takes place between the piston and cylinder wall and the prop shaft and bushings or bearings. Most engines on the market today are classified as ABC meaning they have an aluminum piston and chrome plated bronze cylinder sleeve. This combination normally produces an engine that yields many hours of trouble free operation if properly maintained. Those engines that have ball bearings for supporting the prop shaft normally produce about 25% more power and last much longer.

New .40 size engines can range from \$55 to over \$400. There are several that are accepted due to price, reliability, easy starting, and longevity.

Some of the Best Engines

MANUFACTURER	DESIGNATION	DESCRIPTION
OS	40 FP	Inexpensive, easy to start, reliable, most widely accepted entry level engine
OS	40 LA	Inexpensive, easy to start, reliable, newest entry level engine
OS	40 FX	More expensive, easy to start, reliable, powerful, sport and competition engine
Thunder Tiger	GP42	Inexpensive, easy to start, reliable, fastest growing acceptance for entry level engine
Thunder Tiger	Pro40	More expensive, easy to start, reliable, powerful, sport and competition engine
Magnum	GP40	Least expensive, easy to start, reliable
Magnum	Pro40	More expensive, easy to start, reliable, powerful, sport and competition engine
Super Tigre	GS40	More expensive, reliable, powerful, sport and competition engine
Enya	40TV	More expensive, easy to start, reliable, powerful, sport and competition engine

The entry-level engines are more than adequate for the average trainer and are a good investment. They will normally outlast several trainer airplanes if properly

maintained.

Construction of the Trainer

The subject of actual construction of a trainer is far too involved and lengthy to be covered in depth here. The trainer that the beginner chooses should have a good set of plans and step by step instructions that guide the complete assembly of the trainer including the installation of the radio system. There are many books and articles on this subject that are excellent sources of information. A beginner who has no experience in building balsa models should seek help from an experienced builder to avoid the mistakes that can have disastrous effects.

A beginner should consider using a strong, slow curing adhesive to allow time to correct mistakes during construction. One of the best is an aliphatic resin called Titebond. This cures slowly but yields an exceptionally strong joint and it sands easily after curing. All joints that are subjected to high stresses such as the firewall and center wing joint should be joined with a slow cure epoxy.

The main thing that a beginner must be careful with is the alignment of the wings. Wing alignment is critical in the flight performance and stability of the trainer. The kit's building manual should give detailed instructions as to how this is accomplished and special care should be taken to follow these instructions.

Effects of the Control Surfaces

The new radio systems are proportional control meaning that the control surfaces move in proportion to the amount of movement of the stick. If the stick is moved half of its total travel in one direction, the corresponding control surface will move half of its total travel in the corresponding direction. A beginner must first know the effect that a stick movement has on the model. During normal flight, the throttle is set so that a constant speed is maintained. This means that thrust is equal to drag and lift is equal to weight. From this stable condition, the effects that the stick movements have on the trainer are described.

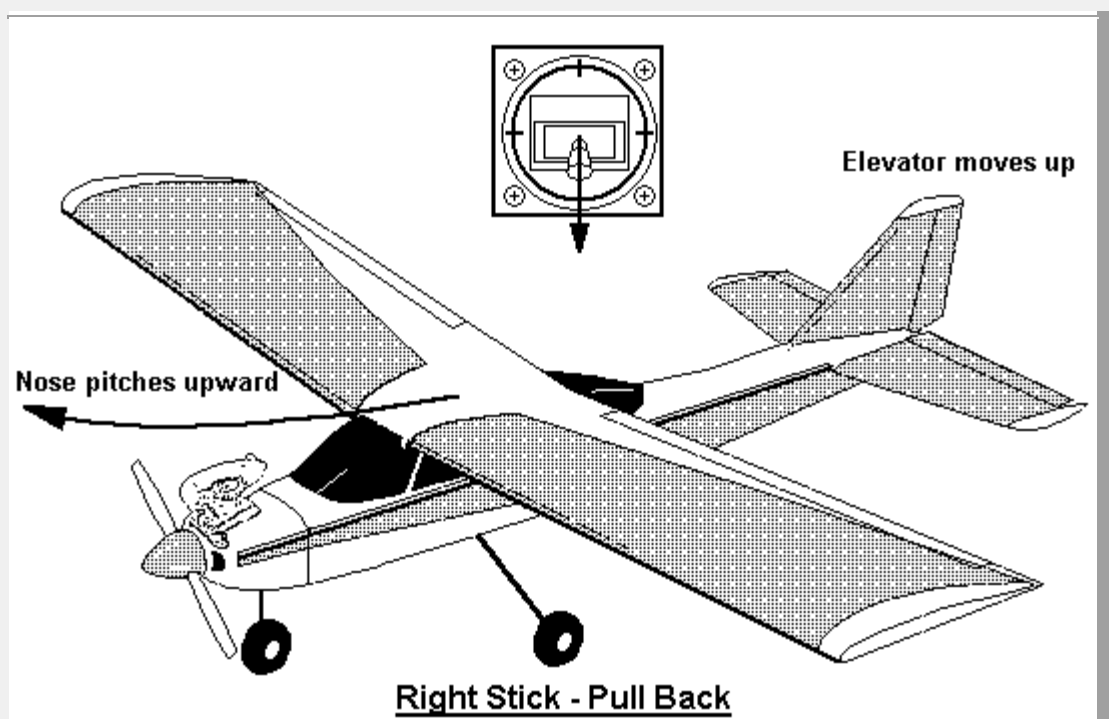

When the right stick is pulled back, the elevator moves up. This causes the nose to pitch upward increasing the angle of attack of the wing and increasing drag. If power is not applied, the airplane will slow down and eventually stall. This means that the air passing over the wing becomes turbulent and lift decreases until weight exceeds lift and the airplane will begin to drop.

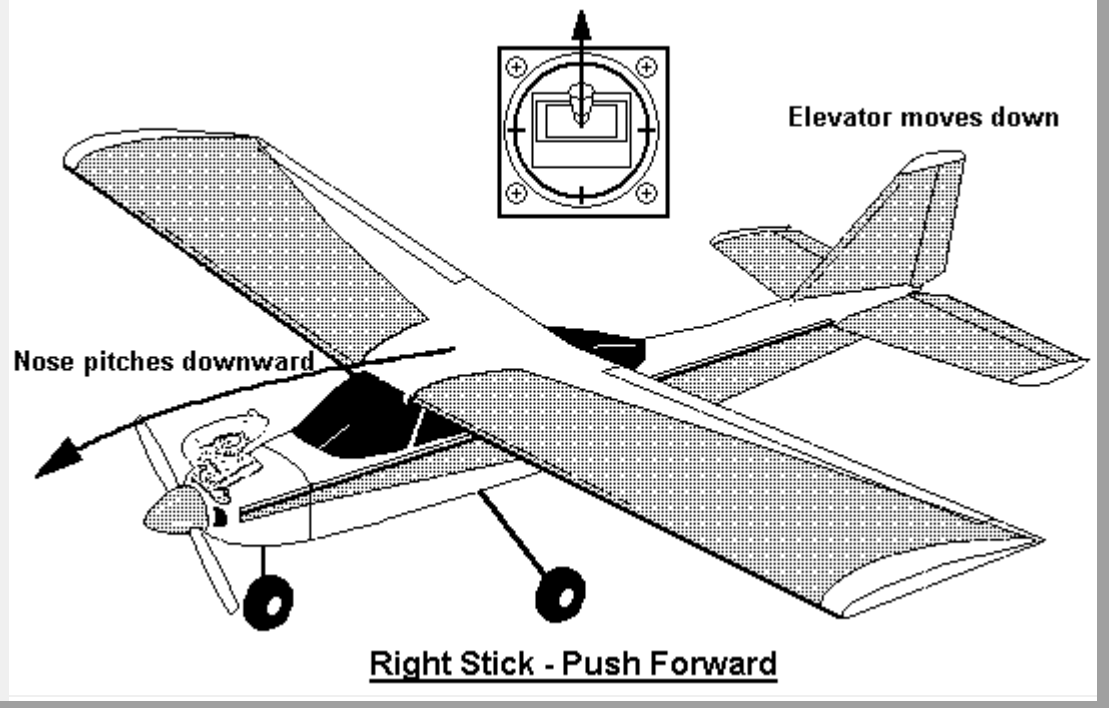

When the right stick is pushed forward, the elevator moves down. This causes the nose to pitch downward reducing the angle of attack of the wing and reducing drag. As the airplane descends its speed increases until drag and thrust are again in balance.

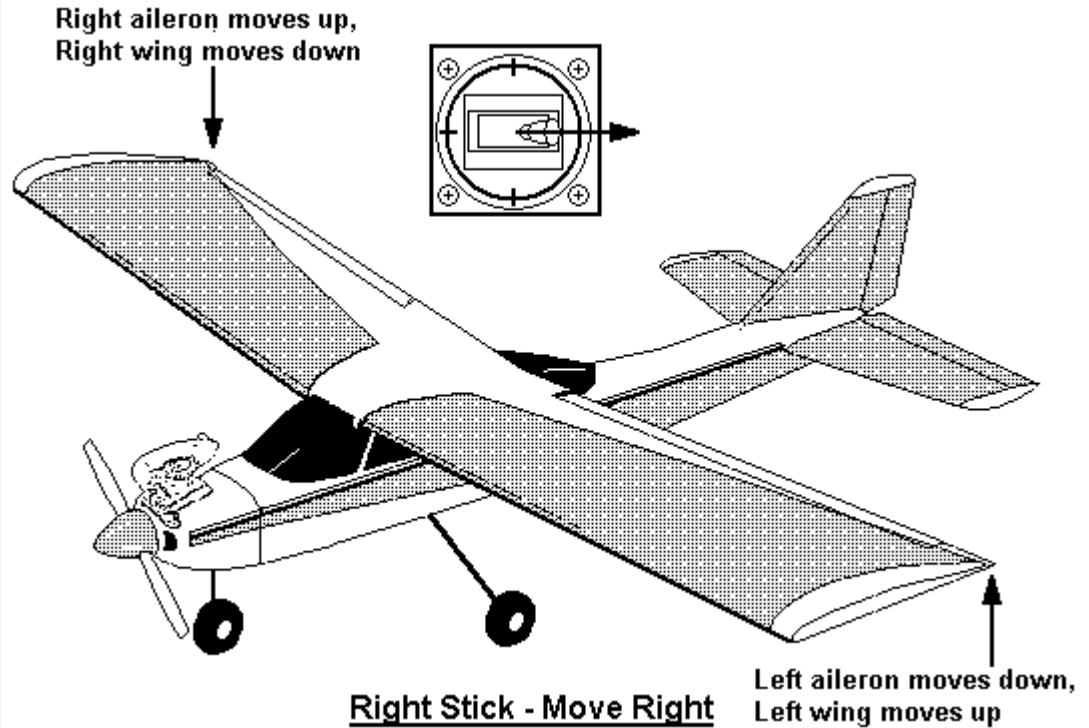

When the right stick is moved right, the left aileron moves down and the right aileron moves up. This causes the airplane to roll to the right meaning that the left wing moves up and the right wing moves down. It will continue to roll as long as the stick is held in the same position. When the roll takes place, lift is no longer oriented vertically so the effective lift decreases. As the angle of the roll increases, effective lift continues to decrease and the airplane will begin to drop.

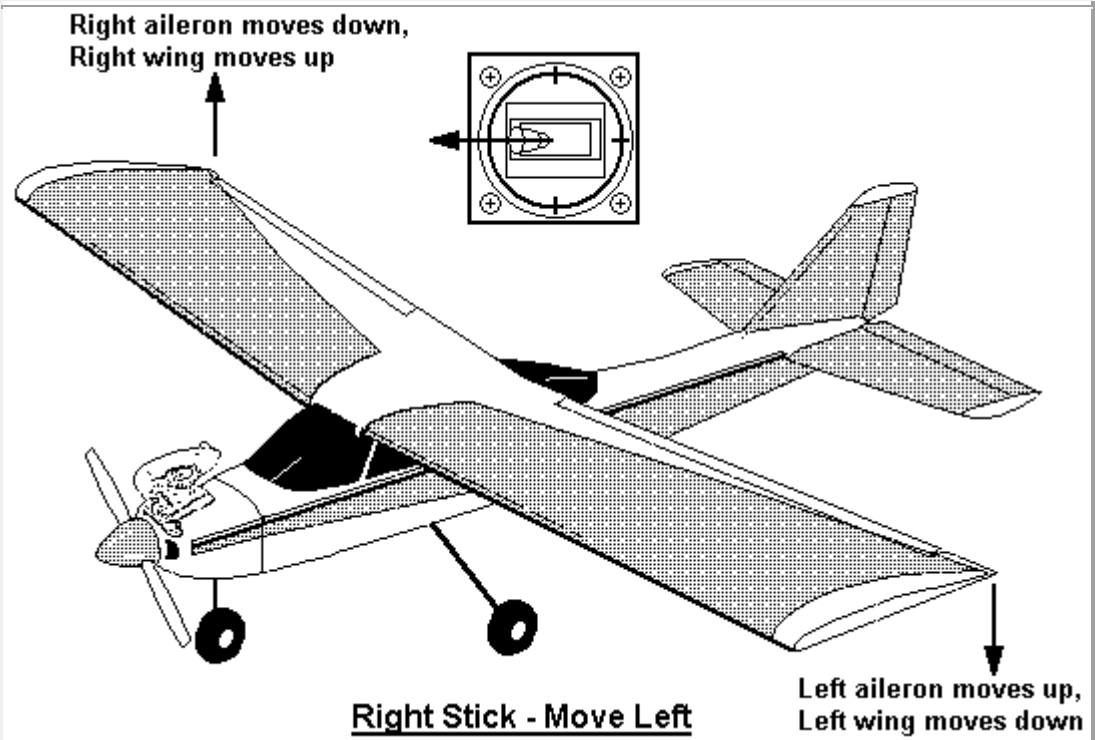

When the right stick is moved left, the left aileron moves up and the right aileron moves down. This causes the airplane to roll to the left meaning that the right wing moves up and the left wing moves down. It will continue to roll as long as the stick is held in the same position. When the roll takes place, lift is no longer oriented vertically so the effective lift decreases. As the angle of the roll increases, effective lift continues to decrease and the airplane will begin to drop.

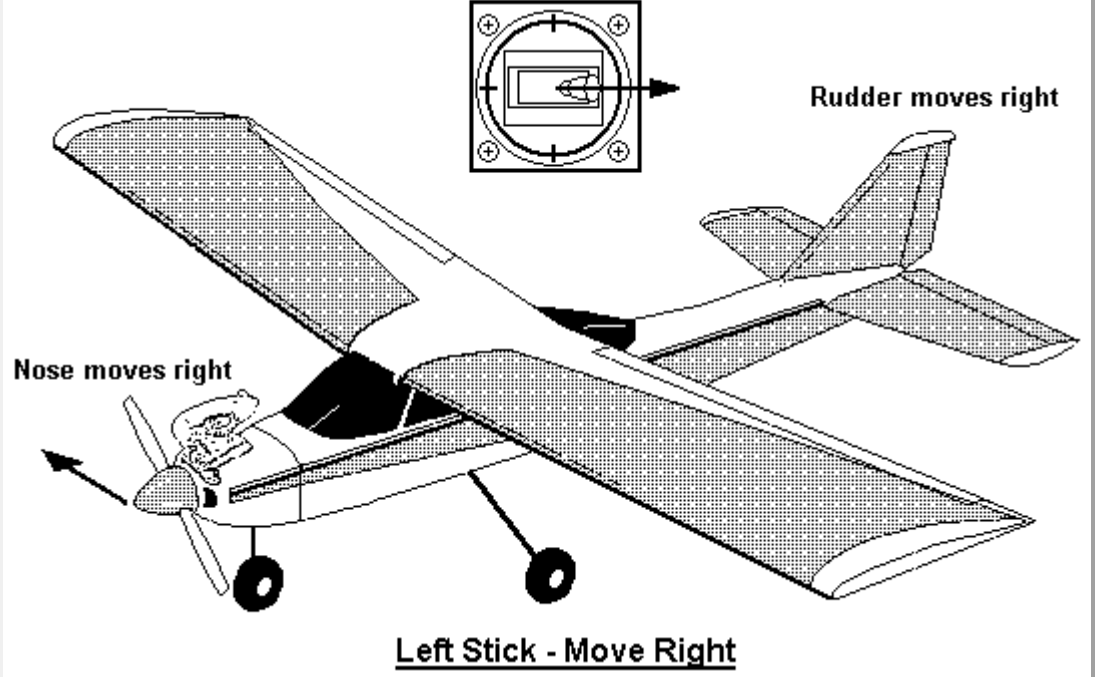

When the left stick is moved right, the rudder moves to the right. This causes the airplane to swing or yaw to the right. This causes the left wing to move slightly faster through the air causing an increase in lift. The combination of the yaw and the lift increase on the left wing results in a gentle turn to the right as long as the stick is held in position.

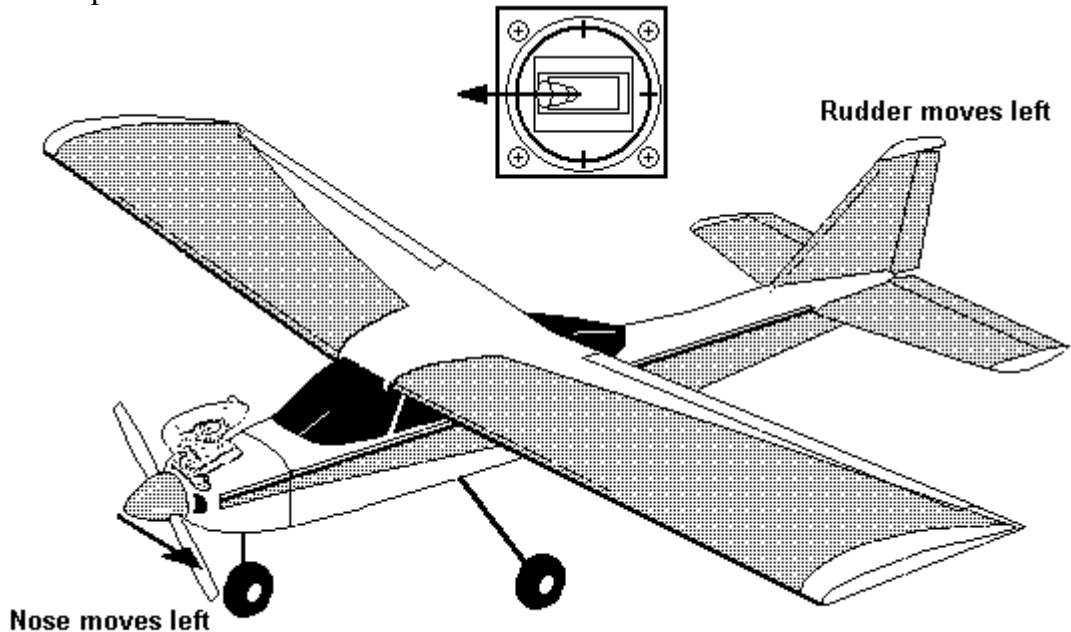

Left Stick - Move Left

When the left stick is moved left, the rudder moves to the left. This causes the airplane to swing or yaw to the left. This causes the right wing to move slightly faster through the air causing an increase in lift. The combination of the yaw and the lift increase on the right wing results in a gentle turn to the left as long as the stick is held in position.

When the left stick is moved forward, the throttle is opened resulting in an increase in speed of the airplane. This causes an increase in lift and results in a tendency for the aircraft to climb. When the left stick is moved back, the throttle is closed resulting in a decrease in speed. This causes a decrease in lift and results in a tendency for the aircraft to descend.

It is obvious from the descriptions of the effects of stick movement, that any movement can adversely affect the flight of a model. These effects can be overcome by using a combination of control surfaces to achieve the desired results. For instance, the right stick can be moved back when it is moved left. The result of this action would be that the nose of the airplane would be raised to overcome the loss of lift resulting in a banked turn without a loss of altitude.

In order to understand how to properly use the controls, a change in thinking may be required of a beginner who has some basic knowledge of control surfaces. A

beginner must remember the forces acting on a model in flight and how they affect the model.

Field Equipment

The equipment required to get a trainer off the ground can be very inexpensive. There are a few basic items that will suffice to get a beginner into the air and learning to fly but there are other items that can be added to make the job a lot easier.

MINIMUM EQUIPMENT

NAME	DESCRIPTION
Glow Plug Driver	Clip on battery for supplying power to glow plug
Chicken Stick	Stick used for flipping the prop to start the engine
Fuel	Fuel mixture recommended by engine manufacturer
Fuel Bulb	Rubber bulb used to transfer fuel to model tank
4 - Way Wrench	Combination wrench with sizes to fit glow plug, prop nut, etc.
Tool Box	Any box suitable for carrying the other equipment

These items should cost about \$50. This can vary depending on the brand of the items and the place from which the items are purchased. An assortment of screwdrivers, pliers, and allen wrenches may also be needed to perform field maintenance.

OPTIMUM EQUIPMENT

NAME	DESCRIPTION
Glow Plug Driver	Clip on battery for supplying power to glow plug
Starter	Battery powered motor for starting model engine
Fuel	Fuel mixture recommended by engine manufacturer
Fuel Pump	Special battery powered pump used to transfer fuel to model tank
4 - Way Wrench	Combination wrench with sizes to fit glow plug, prop nut, etc.
Field Battery	Small 12 volt wet or gel cell battery
Field Charger	Special charger to charge transmitter & receiver battery's
Tool Box	Any box suitable for carrying the other equipment

These items will cost in excess of \$150. The cost will vary depending on the brand of the items and the place from which the items are purchased. Field box kits are available for a wide range of prices but can be built from readily available materials. Plans are available for a simple field box that will fill the needs of a beginner or for a basic necessities field box for a beginner who wants something a little more sophisticated. An assortment of screwdrivers, pliers, nut drivers, and allen wrenches

may also be needed to perform field maintenance.

Learning to Fly

The single most important aspect of learning to fly is getting an instructor. An instructor does not have to be certified to any particular standard but must be a competent experienced R/C pilot who is capable of giving instructions with patience. Many people think that flying R/C models is easy enough that it can be learned without an instructor and many have succeeded but at great expense. Many have become frustrated and disillusioned because of a crash on the first flight and never tried again. This point cannot be stressed enough, that R/C flying is much more difficult than it might seem and that without an instructor to correct mistakes, a crash is inevitable.

There are two ways that an instructor can help a beginner in learning to fly. One way is for the instructor to begin by taking off and turning the transmitter over to the student. When the student has a problem, the instructor takes the transmitter back and takes control of the model. There is a "dead time" that neither the student nor the instructor has control of the model. This can be enough time for the model to crash and be destroyed. The other option is to connect two transmitters together so that the instructor can take control of the model any time that he feels that the student is in trouble. This is the reason that the student should match his radio system to that of the instructor.

Another option available to the beginner is to purchase a buddy box. This is nothing more than a transmitter that has had the battery pack, antenna, and possibly some of the transmitting parts removed. This could be a box that is specifically built for this purpose by the manufacturer of the student's radio system or an old transmitter that has been converted. The big advantage of this is that it allows the student to fly using only his radio gear and not interfering with the instructor's gear. He has the option of using more than one instructor, each of whom might have a different brand of radio. At a cost of \$20 - \$40, this is very cheap insurance against a possible crash.

The last thing that is required of a beginner before he sets out to conquer the world of flight is to join the Academy of Model Aeronautics (AMA) or the Sport Flyers Association (SFA). Each of these organizations provides insurance to cover the cost of a catastrophic incident resulting from a model airplane accident. Very few clubs will allow a beginner to fly at their fields unless this type of insurance covers him/her. Some clubs will only accept one type of insurance, either AMA or SFA. Joining a club is strictly optional but is recommended since this can be a large resource of information. If the beginner can find a suitable place to fly that does not have an ordinance against this type of activity, then a club is not necessary for success. Insurance should not be looked at as an option but as a necessary evil. There are many other benefits offered by the organizations. These benefits are covered by each organization when a contact to the organization is made. The easiest way to find a local club is to ask the owner of a local hobby shop for information. If there is not a hobby shop in the area, the AMA or SFA has information about the clubs.

When the beginner has acquired his equipment, an instructor and insurance and he understands the basics of flight and the use of the controls, he is then ready to start the steps toward becoming a qualified R/C pilot. The instructor to ensure that it works properly should check out each piece of equipment. The airplane must be checked for proper balance then test flown and adjusted for proper flight. If the test pilot feels that there is a serious problem with the aircraft, it must be corrected before the student attempts his first flight. Only after the test pilot has approved all of the equipment and the model should the training begin.

There are a few things that a student pilot should keep in mind when preparing for each flight. These will help in getting the feel for the model in flight.

1. Be **very** gentle with the controls. It takes very little movement to get the model to execute a maneuver. Remember that the farther the stick is moved, the more the control surface moves and the more the model will respond.
2. As long as the stick is held in a control position, the maneuver will continue. This is most important when using the ailerons. When the stick is moved to roll the model, it will continue to roll as long as the stick is held in that position.
3. Fly it in...fly it out. When a maneuver is executed, it takes equal and opposite controls to overcome it and return to normal flight. A turn requires the movement of the ailerons in the desired direction of the turn. To recover from the turn, opposite aileron input is required.
4. Keep the model high. A Certified Flight Instructor once said, "The two most useless things to a pilot are air above you and runway behind you." By this he meant that if a pilot gets into trouble, he must have plenty of air below him to recover. When landing, the runway that is behind the airplane after touchdown is wasted because there is a reduction in length of runway to take off again in case of trouble.
5. Keep the model in sight. Do not fly *too* high nor too far away. Although the trainer may seem fairly large, it is easy to get it far enough away so that it is difficult to see its orientation. Do not fly into the sun. A moment of blindness caused by the sun can be long enough to lose a model.
6. Do not become discouraged. There will be times when nothing seems to go right. Each maneuver results in a near catastrophe. Everyone who flies R/C models today has been through this in learning to fly. Do not give up. The next session will be better.
7. **DO NOT PANIC**. When a maneuver goes wrong, take all the time necessary to recover from the mistake. Panic will cause a student to over-control in an attempt to recover and cause the condition to worsen in the opposite direction. Although the instructor may seem to be a casual observer standing at the side of the student, he will be watching in case the student gets his model in a dangerous situation.

The first few flights will begin with the instructor doing the take-off and checking out the model. The student should watch the airplane as the instructor explains each control movement as it occurs. This will give insight into what is required to execute a take-off. The

same will be true for the landing. Learning to properly land a model is by far the most difficult part of learning to fly. The model is most vulnerable when on the approach to landing because of the close proximity to the ground, its slow airspeed, the reduced responsiveness to control input, and the disorientation due to reversed control.

When the instructor has flown the airplane to sufficient altitude, usually 150 to 200 feet, he will ask the student if he is ready to take control. It is normal to be nervous at this point. Assuming that the student is using a buddy box, the instructor will give control to the student by pressing and holding the trainer switch. He will tell the student the maneuvers that he wants him to perform and how each one is to be done. He will give him instructions as to how to improve each maneuver as it is being done. He will have him perform gentle turns left and right, flying ovals around the field, flying rectangles and figure eights. Each maneuver serves a purpose in building the skill of the student pilot. The student will progress to steeper turns, slow flight and stall recovery, each in itself a maneuver required to learn to land.

If at any time, the student should get into trouble, the instructor can take control of the model simply by releasing the training switch. He can avoid a mishap and take the trainer back to a safe altitude. The instructor will not let a situation build to a point that is beyond his ability to recover yet he will allow the student time to attempt the recovery on his own.

If the student has the time to devote to flying often, he can progress quickly. The day will come when the instructor will allow the student to attempt his first landing. This is a critical time for the instructor since he must react quickly if the student makes a mistake. It may take several attempts before the student actually sets the model down on the runway. Even then, it might bounce and seem to be flying again. Even when this occurs, the student must continue to control the model all the way to the point that it stops rolling.

After what seems like an eternity to the student, the day comes when the instructor is satisfied that the student is proficient enough in his flying skills to fly solo. This can be a harrowing or an exhilarating experience for the student. He feels that he has finally reached his goal but this is only the beginning. At this point, the fun really starts. The student can now spend hour after hour practicing and developing his skills.

Using a Flight Simulator

A flight simulator cannot teach a beginner to fly. There are no magic programs built into a simulator that teach the user the correct way to perform a maneuver or alert the user when a maneuver is done incorrectly. A simulator is exactly what the name implies, a program that simulates the actions of an airplane. It is an easy and convenient way to practice the simplest turns to the most complex maneuvers even when it is dark, wet, windy, cold, etc. A simulator can benefit a beginner greatly if used properly. For a beginner, a simulator can be invaluable in developing approach coordination. When a model is flying toward the flyer or approaching, the controls are backwards. To make the model go to the flyer's right, the stick is moved to the left. Being able to move the stick in the correct direction without thinking takes a lot

of practice. This can be done on a simulator.

There are three (3) commercially available R/C flight simulators that offer simulation of powered airplanes. Each of the simulators is DOS based but will run under Windows 95. The system requirements are 386 processor or higher with a sound card. All simulators use vector graphics to generate the images of the models and the surrounding area. Each one has its own distinctive features, requirements, advantages, and disadvantages. A prospective buyer should examine each of these carefully before choosing the one to buy.

R/C FLIGHT SIMULATORS		
NAME	COST	DESCRIPTION
Ambrosia Aerochopper	\$200	Offered as a complete package including software, Futaba based controller, and instruction manual.
CSM Flight Simulator	\$200	Offered as a complete package including software, adapter for user's transmitter, and instruction manual.
Dave Brown RCFS	\$150	Offered as a complete package including software, dual joystick controller, and instruction manual. Software can be purchased separately for about \$64.
RealFlight	\$250	Offered as a complete package including software, dual joystick controller, and instruction manual. Software can be purchased with a transmitter interface for \$190.
RealFlight Lite	\$100	Offered as a complete package including software, dual joystick controller, and instruction manual. Planes cannot be modified. Selection is sparse.

A beginner can benefit from the use of an R/C simulator by using it between flying sessions to practice the things that he has been taught by his instructor. Using the instructions he has been given, he should practice only those things that he has been taught while working to improve coordination and developing a feel for each maneuver. He can use it prior to a flying session to build confidence in his ability to control the model.

Getting Started

With the help of experienced modelers, a beginner should be able to make a somewhat educated guess as to which trainer system best fits his needs. There are many sources from which a beginner can purchase the equipment that he will use to begin the hobby. Most people live in or near a city that has a hobby shop that carries R/C equipment. The prices may be higher than those from a mail order house but the owner of the shop can be a big benefit to the beginner. Mail order houses usually have a larger selection than local hobby shops but the beginner must know exactly

what he wants to buy and place the order for everything at the same time to avoid incurring multiple shipping charges.

When a beginner makes the decision to become involved in R/C aircraft modeling, he must be willing to devote his time and money to the hobby. He must be willing to tolerate disappointment and frustration. Although R/C modeling can be frustrating and disappointing at times, it can be very rewarding and a lot of fun.



*Developed by [Geistware of Indiana](#)©., 1999.
Updated July 8, 2003*